



Official State Historical Center of the Texas
Rangers law enforcement agency.

**The Following Article was Originally Published in the
*Texas Ranger Dispatch Magazine***

The *Texas Ranger Dispatch* was published by the Texas Ranger Hall of Fame and Museum from 2000 to 2011. It has been superseded by this online archive of Texas Ranger history.

Managing Editors

Robert Nieman 2000-2009; (b.1947-d.2009)

Byron A. Johnson 2009-2011

Publisher & Website Administrator

Byron A. Johnson 2000-2011

Director, Texas Ranger Hall of Fame

Technical Editor, Layout, and Design

Pam S. Baird



Funded in part by grants from
the Texas Ranger Association Foundation

Copyright 2017, Texas Ranger Hall of Fame and Museum, Waco, TX. All rights reserved. Non-profit personal and educational use only; commercial reprinting, redistribution, reposting or charge-for-access is prohibited. For further information contact: Director, Texas Ranger Hall of Fame and Museum, PO Box 2570, Waco TX 76702-2570.



A Unique Colt 1860 Richards Transition Army Conversion

David Stroud

All photos courtesy of David Stroud

In the 2005 summer issue of the *Dispatch*, my article about a converted Whitney revolver was published. In the introduction, I mentioned an old 1860 Army Colt Conversion with nickel “R” and “S” depressions in the wood grip. That was my first antique Colt, and a few years later, I traded it for a First Model Colt Dragoon at Jackson Arms in Dallas. I needed the trade to help offset the cash difference, but I never forgot that old Colt. The salesman had told me, “It’s a Conversion; nobody wants them.”

During the 1960s, 1970s, and even into the 1980s, Colt Conversions were considered by collectors as the ugly ducklings of Colt firearms.¹ It was true: no one wanted them. Even the owner of a factory-engraved 1860 Colt Army with 65% finish in perfect working order was unable to sell his gun for \$50.00 over his purchase price of \$185.00. He was told that it wasn’t worth that kind of money, and the engraving didn’t add anything to its value.² Collectors considered Conversions as non-original Colts, much like flintlocks that were converted to percussions, or even worse, flintlocks

1 David Stroud, “Colt’s Lightning” *Dispatch*, Spring 2003. <http://www.texasranger.org/dispatch/10/Pages/ColtLightning.htm>

The Colt Lightning and the Colt Thunder were also considered Old West undesirables.

2 R. Bruce McDowell, *A Study of Colt Conversions and Other Percussion Revolvers* (Iola Wisconsin: Krause Publications, 1997), introduction.



converted to percussions during period of use and then reconverted back to flintlocks during the 20th century. One's money was better spent on original, lesser conditioned Colt cap-and-ball revolvers or single-action Armies.³

Those days are gone and they're not coming back. Colt Conversions have become very desirable, and in some cases, even more so than some of the percussion Colts. Blacksmith conversions with shortened barrels and belly guns with only a hint of a barrel are eagerly sought after by today's collectors.

There are several reasons these ugly ducklings have become beautiful swans. As the price of antique weapons increased, modest-income collectors turned to the less costly examples and were able to purchase better conditioned Colt Conversions for less money than antebellum Civil War and Single-Action Armies. The percussion Colts were converted in 1868-1873, an extraordinarily short period of time. During these years, Old West gunfights began, and this adds great interest to these relatively rare revolvers. In fact, there were forty-eight Western gunfights between 1854 and 1867 and ninety-six from 1868 through 1873. In that time, thirty-four of the all the encounters were in Texas.⁴ Those years only encompass Colt's Single-Action Percussions being converted into single-action, metallic-cartridge firing revolvers by the factory. However, Colt Conversions were used by gun-carrying individuals for many years after the introduction of the Colt Single-Action Army in 1873.⁵

The reason Colt began converting cap-and-ball percussion revolvers to fire metallic cartridges during 1868 is that Smith and Wesson's patent protecting their invention of an "improved self-contained centerfire metallic cartridge" expired that year. However, Rollin White's patent protecting his invention of "extending the chamber of the rotating cylinder right through the rear of said cylinder for the purpose of enabling the said chamber to be charged at the rear either by hand or by a self-acting charger" did not run out until 1869.⁶

With the expiration of Smith and Wesson's patent, the Colt factory began producing its first Conversion, known to collectors as the Thuer Conversion. Without violating White's patent, F. Alexander Thuer had patented his design of loading a metallic cartridge through the front of the cylinder.⁷ Colt manufactories were eager to produce self-exploding, metallic-cartridge handguns, so rather than wait until White's patent expired, they began converting their large stock of unsold percussion revolvers by Thuer's method. Therefore, Thuer Conversions were the first to be offered in 1868.⁸

3 Colt was considered the collectable of collectable revolvers in the 1960s through the 1970s and much of the 1980s. Remingtons were a distant second; then Smith and Wesson's, Manhattan Fire Arms. Flintlocks converted to percussions during period of use were undesirable, but those reconverted back to Flintlocks by dealers in the 20th Century to sell as original Flintlocks were—and still are—considered the worst type of Conversions.

4 Bill O'Neal, *Encyclopedia of Western Gunfighters* (Norman, Oklahoma: University of Oklahoma Press, 1979), 10-11.

5 O'Neal, 10-14. Bill O'Neal defined the Old West Gunfighters Period as the years 1854-1924.

6 McDowell, 8. White had entered into an agreement with Smith and Wesson, giving them permission to produce bored-through cylinders for twenty-five cents a revolver until his patent expired.

7 R. L. Wilson, *Colt: An American Legend* (New York: Abbeville Press, 1985), 157.

8 Charles T. Haven and Frank A. Belden, *A History of the Colt Revolver and Other Arms Made by Colt's Patent Fire Arms Manufacturing Company from 1836 to 1940* (New York: Bonanza Books, 1940), 130-132. Thuer cartridges that could be reprimed and reloaded were also produced.

However, before the 1860 Army (contemporarily listed as New Model Holster Pistol and New Model Army Pistol⁹), there had to be 1860 Armies to convert. Those lighter-weight, .44 caliber

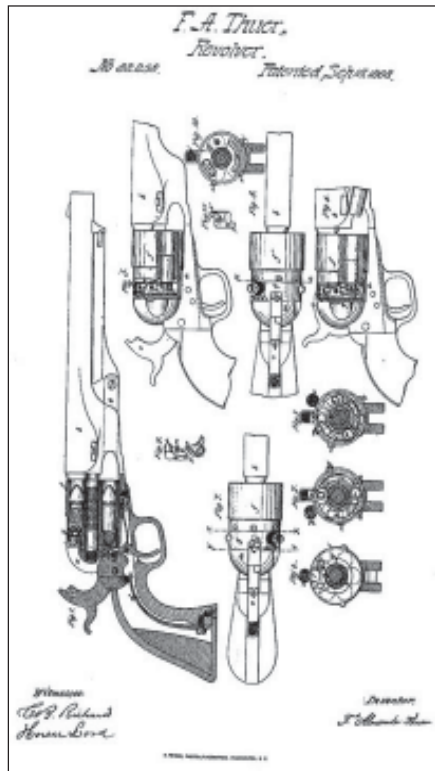

Thuer Revolver

handguns became possible with the introduction of silver spring steel. This new material allowed Colt to produce two-pound, two-ounce, Army-caliber revolvers to replace the Walkers (four pounds, nine ounces) and three Dragoon models (four pounds, two ounces¹⁰) on the eve of the Civil War. The popularity of the Colt Army during that bloody conflict is historically documented by the 127,157 of them purchased by the US War Department, 997 by the US Navy, and another 1,064 sold through open markets between 1861 and 1865. This was a grand total of 200,500 before production halted in 1873.¹¹ Add to those numbers privately purchased 1860 Armies during the war, and the total becomes 153,000.¹² No other handgun neared those sales during 1861-1865.

Little wonder that Colt management realized the instant popularity of an Army Colt firing the metallic cartridge. The most economical way to produce them was converting inventoried 1860 Armies by Thuer's method of alteration. This incorporated the method of building unassembled 1860 Armies to fire metallic cartridges rather than percussion caps, which ignited black powder to fire a lead ball seated in the cylinder's chamber.

As previously stated, because Smith and Wesson's patent would not expire until 1869, the Thuer method was incorporated to produce cartridge-firing 1849 Pockets (.31 caliber) 1851, 1861 Navies, 1862 Pocket Navies (.36 caliber), 1860 Armies (.44 caliber), and a few Walkers, Dragoons, and 1855 Side Hammer Roots (.28 and .31 caliber). The approximate total was 5,000 between 1868 and 1871.¹³

Thuer-altered Colts never gained the popularity the company hoped for. With the Rollin White patent expiring on April 3, 1869, Colt began designing metallic-cartridge revolvers with bored-through cylinders for production.¹⁴ The first of several types of converted Armies to be offered by Colt was the Richards Conversion.

9 Haven and Belden, 101. *Army* meant .44 caliber.

10 Haven and Belden, 50, and Tom LoPiano "Traitor or Capitalist: An Inscribed Colt Model 1860 Army from a Shipment of 500 to Richmond, Virginia, on April 15, 1861," *Man At Arms*, XXXI (No.1, 2009), 40.

11 John D. McAulary, *Civil War Pistols* (Lincoln, Rhode Island: Andrew Mowbrary, Inc., 1992), 37, 44. and Norm Flayderman, *Flayderman's Guide to Antique American Firearms...and their value, 8th edition* (Iola, Wisconsin: Krause Press, 2001), 80.

12 Wilson, 365.

13 Wilson. 364.

14 McDowell, 137.

Because of the rarity and relative high price of Thuer Conversions, many unscrupulous dealers have produced fakes, and sadly a few collectors have unknowingly purchased them.



Richards J

Charles B. Richards was an inventor employed by Colt and serving as assistant factory superintendent at the dawn of the metallic-cartridge age. He had been awarded three patents by the fall of 1871: a breach-lading firearm in August 1868; the Richards Conversion in July 1871; and the House Pistol, also called the Cloverleaf because of the shape of its cylinder.¹⁵

The Richards method of converting 1860 Army Colts required a rebounding firing pin, a new breech plate that collectors call a conversion ring, and a complex cartridge extractor assemble.¹⁶ The conversion ring has an assembly number stamped on its outside, the loading gate, the cylinders back, under the barrel, the underside of the frame, the cylinder arbor, and the top of the ejector assembly. The revolver's serial number is found in the usual places for a Colt Army.¹⁷ The left side of the frame has the original Colt patent stamped in two lines without the Richards patent dates.¹⁸ The serial numbers for the Richards Army Conversions are from 1 to a high 5,000. They were advertised as Colt's Metallic Cartridge Revolvers, and an ad for 1872 Colts priced them at \$16.00 for a non-engraved with standard grips.¹⁹

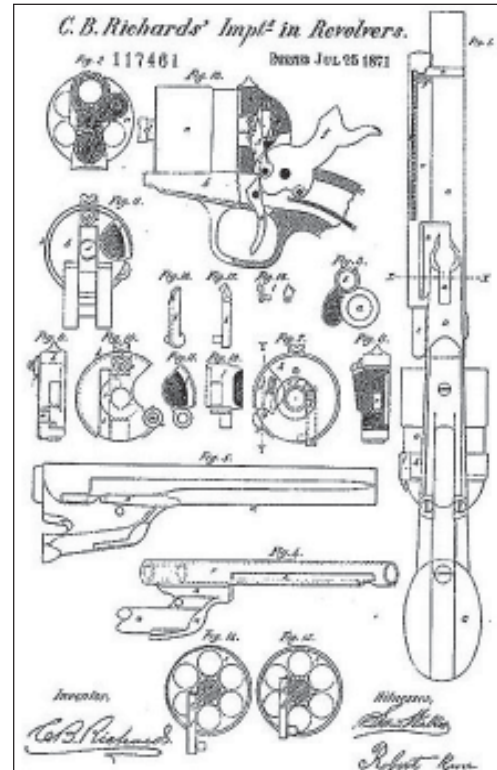

Richards Revolver

15 McDowell, 137.

*The House Pistol was .41 caliber and produced by Colt in the early 1870s.

Haven & Belden, 167.

16 McDowell, 139, 198.

17 McDowell, 161, 169.

18 McDowell, 152-153.

19 McDowell, 158-159.

The illustrated ad shows a sketch of a Richards Conversion fitting this description. In 1860, non-skilled workers averaged between nine and fourteen cents per hour for six ten-hour days. A laborer would have to work about 130 hours to pay for the 1860 Army Colt Conversion had it been available for that price in that year.

Herbert G. Houze, *Colt Presentations from the Factory Ledgers 1859-1869* (Lincoln, RI: Andrew Mowbray, Inc. 2003. 17 (Note: Hourly wages and work weeks were probably the same in 1872.)

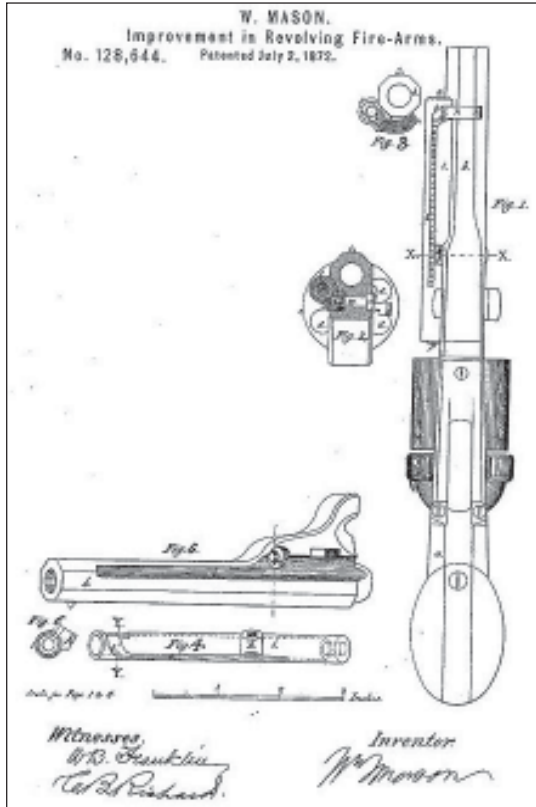

Mason Revolver

with the “S” contour, two-line patent dates with dashes on the left of the frame, and this inscription on top of the barrel:

-COLT'S PT.FA. MFG. CO. HARTFORD. CT.U.S.A.-

Many collectors consider that the Conversion era ended in 1871 when the company began manufacturing the .44 caliber Open Top rimfire revolvers. However, both Richards and Richards-Mason Conversions were also still in production.²⁵ Open Top revolvers are similar in appearance to 1851 Navy Conversions with the exception of a rear sight on top of the barrel near the cylinder. However, they were classified as non-converted revolvers on the eve of Colt Single-Action Army production because the cylinders, barrels, and frames were constructed only for metallic rimfire cartridges, with grip assembly and internal parts identical to 1851 Navies and 1860 Armies.²⁶

²⁰ McDowell, 198.

²¹ McDowell, 198.

²² McDowell, 198. Typos magically appear in books after publication. The text date for the Mason patent is July 2, 1862; however, the patent illustration is dated, July 2, 1872.

²³ McDowell, 198-199. (A detailed listing of each of these revolvers.)

²⁴ McDowell, 199-200. (A complete list on the Richards-Mason 1860 Army Colt's features.)

²⁵ McDowell, 206.

²⁶ Wilson, 164-165, 364.



As previously stated, all Colt Conversions are relatively rare when compared to the production of Percussion revolvers and Single-Action Armies. The total number of Conversions is 46,100, which includes the following:

- Police and Pocket Navies the largest number (24,000) produced in .38 caliber.
- Thuer Conversions 5,000 in all calibers
- Richards Conversions 9,000
- 1851 Navy Richards-Masons 3,800
- 1861 Navy Richards-Masons 2,200
- 1871-1872 Open Tops just under 6,000
- Richards Transition Conversions 2,100 (the fewest converted Colt's manufactured)²⁷

The featured gun in this article, a Richards-Mason 1860 Army Colt, maintains the Richards barrel and ejector but has the Richards-Mason hammer. The left side of the frame has the Colt patent and the two Richards-Mason patent dates of July 25, 1871/July 2, 1872, in two lines. There is no assembly number, but "195881," its serial number, places it during the 1872 percussion production year and is stamped in the usual place for an 1860 Army Percussion. The last four numbers, "5881," are on the surface of the cylinder where the Colt patent and the Texas and Mexican Naval battle scene appeared before they were gradually worn off by use. Those last four serial numbers are also stamped on the Conversion's ejector housing (loading gate), unlike the assembly number that Colt factory-converted percussions have. The barrel address is the same as cap and ball Colts and Open Tops:

—ADDRESS COL. SAM COLT NEW YORK U.S. AMERICA—

This is not the address found on inventory Percussion 1860 Army Colts converted to fire metallic cartridges by the Richards-Mason method. Although the well used but not abused featured



Richards address

²⁷ Wilson, 163

Flayderman, 85. Although the Richards-Mason Transition is the rarest revolver produced during the Conversion period, collectors value the Thuer and Open Top more.

Colt appears to be a Mystery, the serial number places it 2,381 numbers above the last known Mystery Conversion, and it has the two-line patent dates that neither Mysteries nor Blacksmith Conversions have.²⁸ Therefore, the explanation may be that the Colt was purchased as a cap-and-ball and later returned to Colt for conversion during the Richards-Mason transition period. Therefore, there was no need for the “S” contoured barrel, serial number, or an assembly number. The Richards-Mason production era was brief, and only a few variations are known.²⁹ The gun featured in this article may be one of those few.³⁰

Because many Colt Conversions saw heavy use and ill treatment in Texas, Mexico, and the western frontier during the 1870s and 1880s, they are generally found in poor to fair condition. However, slight or careful handling may have left them in fine condition with the majority of original Colt finish still present.³¹

The featured Colt is in the former category of heavy use with no finish, no cylinder scene, and a well-worn barrel address. Nevertheless, it is not abused. There are reasons for my assessment. The letters “D” and “V” have been scratched into the brass trigger guard strap, with the “D” scratched into the brass forward of the trigger guard. The two parallel scratches on the brass strap behind the trigger guard appear to be either “V” or an uncompleted “A.” Needless to say, these could be the initials of one owner who spent more time on the “V” (or “A”) than the “D.” They could also be the initials of two separate owners of the Colt. We know there were numerous outlaws, lawmen, and Texas Rangers whose names contained those letters during the Colt Conversion period and into the early years of the Single-Action Army.³²

The Texas Ranger Hall of Fame Museum has one of the finest collections of firearms to be found anywhere. Several Colt Conversions and Open Tops are displayed for readers who wish to see the firearms bridge between percussion Colts and the Single Action Army as well as other Colts that both predate and postdate Conversions.³³ A visit to the museum is well worth the time.



Double V

28 McDowell, 399. Mystery-converted 1860 Armies and 1861 Navies have serial numbers 152,000-193500 and are non-factory conversions. McDowell classifies Blacksmith Conversions as Private Conversions.

29 McDowell, 206.

30 A Colt letter may solve the mystery. However, living up to my *Dispatch* nickname, “Deadline,” I’ve not yet sent for one. When I do and if the information solves the mystery, I’ll provide an update in the *Dispatch*.

31 McDowell, 323.

32 O’Neal, 6.

33 R. Bruce McDowell’s *A Study of Colt Conversions and Other Percussion Revolvers* is an outstanding, in-depth study of Colt Conversions as well as others such as Remington, Cooper, Freeman, Rogers and Spencer, Starr, and Whitney foreign Conversions.